



## DATI TECNICI - TECHNICAL DATA

BAND: bandelle / fixing bands		
<b>cod. 80800b00000</b> Bandella metallica perforata in dispenser <i>Fixing Band</i>	<b>cod. 80800b00001 / 80800b00002</b> Bandella metallica perforata in dispenser <i>Fixing Band</i>	<b>cod. 80803015010</b> Bandella in tessuto <i>Textile band</i>
		

Descrizione <i>Description</i>	Materiale <i>Material</i>	w [mm]	L [m]	t [mm]	S [mm]	df1 [mm]	df2 [mm]	Cod.
Bandella metallica - Dispenser in plastica <i>Fixing band - Plastic dispenser</i>	nastro perforato zincato bianco EN10142-DX51D-ZF225 <i>white zinc plated perforated tape</i> EN10142-DX51D-ZF225	12,0	10	0,7	9,0	5,0	-	80800b00000
Bandella metallica - Dispenser in plastica <i>Fixing band - Plastic dispenser</i>	nastro perforato zincato bianco EN10142-DX51D-ZF225 <i>white zinc plated perforated tape</i> EN10142-DX51D-ZF225	17,0	10	0,7	12,0	6,3	3,0	80800b00001
		25,0	10	1,0	14,0	8,5	4,0	80800b00002
Bandella in tessuto <i>Textile band</i>	polipropilene <i>polypropylene</i>	15,0	10	1,3	-	-	-	80803015010

BAND: accessori / accessories	
<b>cod. 35220e</b> Chiodo a percussione <i>Impact nail</i>	<b>cod. 49929</b> Percussore per chiodo <i>Impact nail setting tool</i>
	

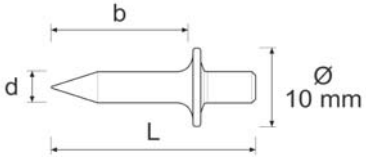
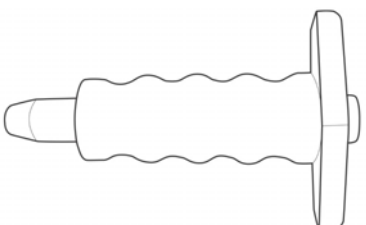
Descrizione <i>Description</i>	Materiale <i>Material</i>	L [mm]	b [mm]	d [mm]	Cod.
Chiodo a percussione <i>Impact nail</i>	Acciaio (C72) temprato brunito (durezza HRC: 55-59) zincato nero ISO 4042 <i>Hardened steel (C72) burnished (HRC hardness 55-59)</i> <i>Black zinc plated ISO 4042</i>	22	14	4	35220e04014
		26	18	4	35220e04018
		30	22	4	35220e04022
		35	27	4	35220e04027
Percussore per chiodo <i>Impact nail setting tool</i>	Paramano in gomma Utensile in acciaio (C70) temprato e zincato (durezza HRC: 59-60) <i>Rubber hand guard</i> <i>Tool in hardened zinc plated steel (C70) (HRC hardness 59-60)</i>				49929000000